

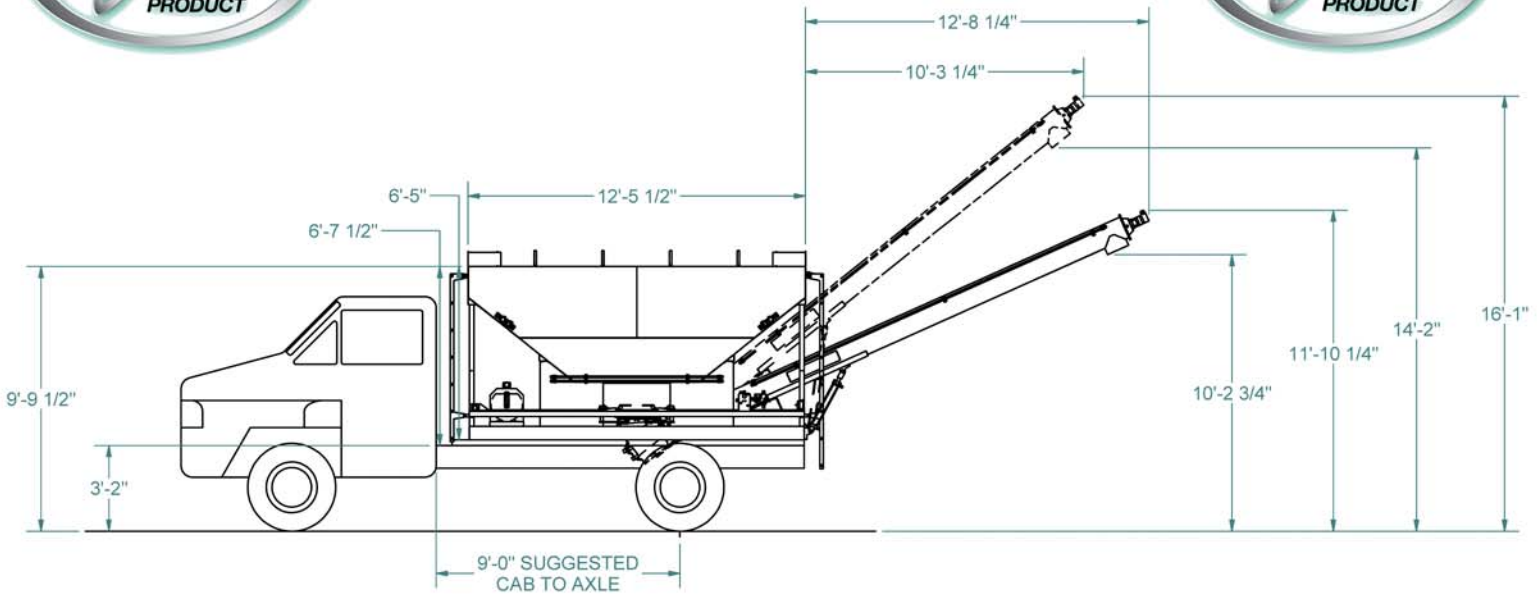

CAPACITY



Hopper capacity (water level).....330 Cubic Ft.



HOPPER DIMENSIONS

Hopper length..... 12.46 ft. (3.79 m)
 Hopper width..... 8 ft. (2.44 m)

AUGER SPECS

Based on truck frame height of 38 in.

Tube size..... 10 in. (254 mm)
 Discharge rate..... 3,500 lbs./min. (1,588 kg/min.)
 Discharge height (maximum)..... 14.1666 ft.(4.32 m)
 Discharge height (minimum)..... 10.2291 ft.(3.12 m)
 Auger length..... 20 ft. (6.09 m)

STANDARD FEATURES

- Stainless gate slides
- Stainless gate fasteners
- Stainless hopper boot
- Stainless hanger pipes
- Fenders, with Doyle mud flaps
- Mounted S.R.T. roll tarp with stainless steel end caps
- 10" stainless steel auger tube with stainless steel flighted auger
- Stainless gate sleeves
- Stainless transition box
- 2"x6" sqr. tubing frame capped on ends
- Front and rear mounted ladder
- Auger clean-out door
- Two compartment hopper

