

Doyle Bucket Elevators

Standard Features & Dimensions For The 90 & 120 TPH Model Bucket Elevator

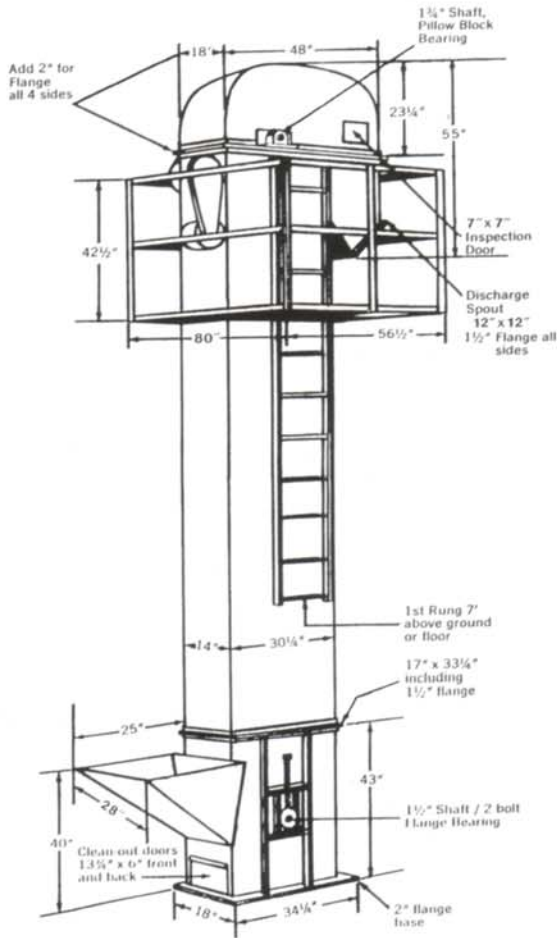

90 & 120 TPH Head Section

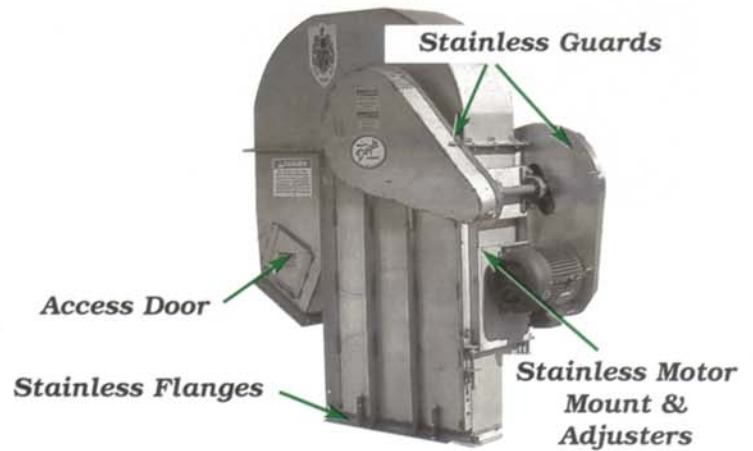

Buckets, Regular & Digger



Polyethylene buckets (L) can operate in temperatures from -60 degrees F to +200 degrees F and are designed for centrifugal discharge elevators. (R) Stainless digger buckets are sometimes used, normally every tenth bucket.

Elevator Head & Boot Pulley*

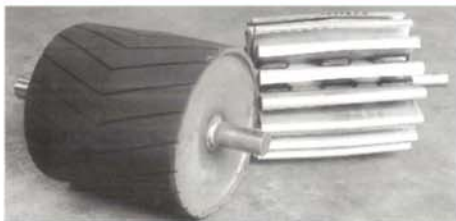

*90 & 120 TPH models only

Left: Head Pulley Is Rubber Lagged & Crowned.
Right: Boot Pulley Is Stainless Steel & Self-Cleaning.

Valves & Accessories



Three Way Valve



Distributors

Doyle offers a full line of valves, elbows, spouts, etc.

Doyle Equipment Mfg. Co., Inc.

P.O. Box 3024 • 3900 Broadway

Quincy, Illinois, USA 62305

217-222-1592, Fax 217-223-3655

E-mail: doyle@rnet.com • Website: www.doylemfg.com

