

Doyle Shamrock Dimensions & Options

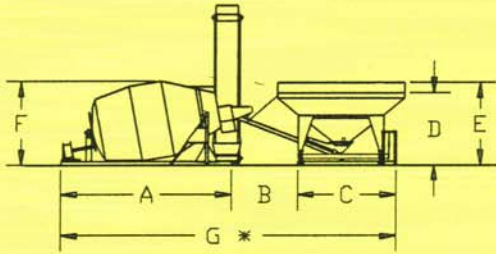

Doyle SHAMROCK SYSTEM DIMENSIONS													
	A	B	C	D	E	F	G	H	I	J	K	L	M
2 TON	11'-4"	7'-4"	6'-9"	6'-5"	7'-1"	6'-4"	25'-5"	7'-11"	5'-8"	18'-3"	14'-3"	18'-3"	4'
5 TON	13'-4"	7'-4"	6'-9"	6'-5"	7'-1"	7'-9"	27'-5"	7'-11"	7'-1"	20'-3"	14'-3"	20'-3"	4'
6 TON	14'-10"	5'-9"	9'-3"	6'-11"	6'-11"	7'-9"	29'-10"	7'-11"	7'-1"	25'-8"	18'-4"	30'-7"	6'
8 TON	16'-4"	5'-9"	9'-3"	6'-11"	7'-11"	8'	31'-4"	7'-11"	7'-1"	27'-2"	18'-4"	32'-1"	6'
10 TON	19'-2"	5'-9"	9'-3"	7'-7"	8'-11"	8'-3"	34'-2"	7'-11"	7'-1"	30'	18'-4"	34'-11"	6'

* = Minimum pad dimensions

Note: For "MAGNUM" or "CYCLO" dimensions consult factory.

* = W/ Telescopic Downspout (In up position) (Add 36" for down position)

STANDARD SETUP

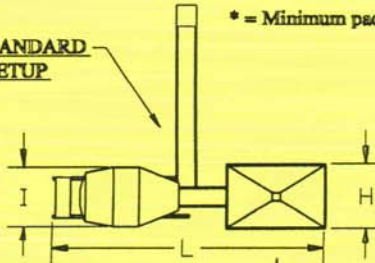

RIGHT ANGLE SETUP

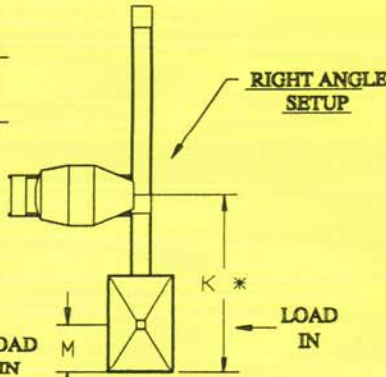

IN-LINE SETUP

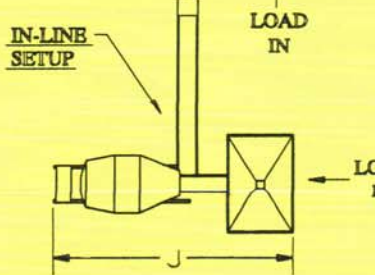

* = Requires 14' Transfer Conveyor

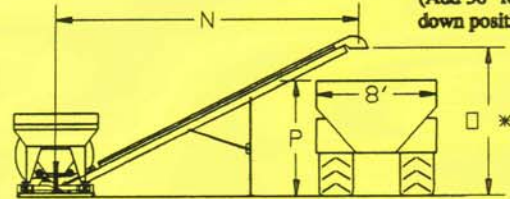

CONVEYOR DIMENSIONS				
	N	O	O*	P
24'	22'-10"	11'-4"	9'-4"	9'-3"
27'	25'-6"	12'-8"	10'-8"	10'-7"
30'	28'-2"	14'	12'	11'-11"
32'	29'-7"	14'-11"	12'-11"	12'-10"
36'	33'-7"	16'-9"	14'-9"	14'-8"
40'	37'-1"	18'-7"	16'-7"	16'-6"



Chainbelt Tri-Roll Trough

Optional Available Conveyor Styles

Optional Challenger Weigh Hopper



Optional Direct Discharge To Leg



Conditioner Option

Doyle Conditioning Weigh Hoppers allow fertilizer dealers to use more of their inventory, while giving customers the quality of fertilizer required for today's planter boxes. It comes complete with a 10 h.p. motor, model 3 gear box, and a 16" diameter, reverse flighted auger. This auger runs horizontally at a gentle 52 RPM, gently breaking up chunked fertilizer by bringing it to the center, where a paddle breaks chunks. The 7 ga. stainless side screens allow good fertilizer to pass through their 3/4" holes without being processed by the auger.

